

Technical data sheet

Product features



Slicer gear, blade 300 mm teflon

Model	SAP Code	00014116
--------------	-----------------	----------



- Blade type: Teflon
- Blade diameter [mm]: 300
- Cutting thickness [mm]: 0 - 14
- Useful Cut [mm]: 265 x210
- Transfer type: Snail
- Material: Aluminium
- Safety cover: plastic
- Safety element: motor with fan and overheating protection
stainless steel blade guard
transparent finger protection
- Suitable consumer: vhodné pro velké provozovny
- Table position: Oblique
- On/Off button: Yes
- Continuous work limit: doba chodu bez omezení

SAP Code	00014116	Loading	230 V / 1N - 50 Hz
Net Width [mm]	580	Blade type	Teflon
Net Depth [mm]	480	Blade diameter [mm]	300
Net Height [mm]	515	Cutting thickness [mm]	0 - 14
Net Weight [kg]	20.80	Useful Cut [mm]	265 x210
Power electric [kW]	0.320		

Technical data sheet

Technical drawing



Slicer gear, blade 300 mm teflon

Model

SAP Code

00014116

Model	A	B	C	D	E
GMS 220	275	375	380	445	370
GMS 250	275	430	425	525	380
GMS 275 XL	350	490	480	510	400
GMS 300	350	490	480	580	515

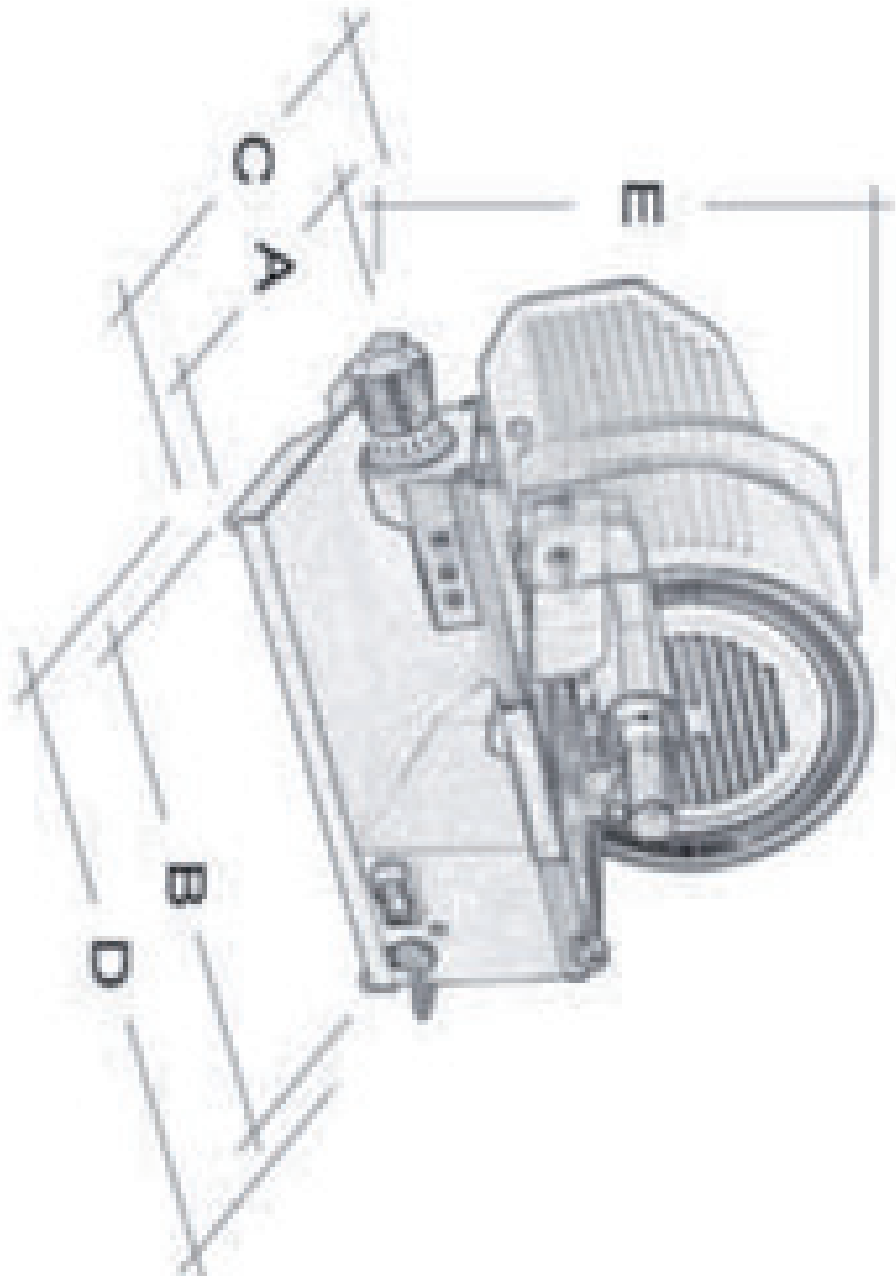

Technical data sheet

Technical parameters



Slicer gear, blade 300 mm teflon

Model

SAP Code

00014116

1. SAP Code:

00014116

2. Net Width [mm]:

580

3. Net Depth [mm]:

480

4. Net Height [mm]:

515

5. Net Weight [kg]:

20.80

6. Gross Width [mm]:

610

7. Gross depth [mm]:

530

8. Gross Height [mm]:

560

9. Gross Weight [kg]:

23.40

10. Device type:

Electric unit

11. Material:

Aluminium

12. Power electric [kW]:

0.320

13. Loading:

230 V / 1N - 50 Hz

14. Control type:

Mechanical

15. Safety cover:

plastic

16. Safety element:

motor with fan and overheating protection
stainless steel blade guard
transparent finger protection

17. Suitable consumer:

vhodné pro velké provozovny

18. Engine protection:

fan and overheating protection

19. Adjustable feet:

No

20. Start /stop:

Yes

21. Transfer type:

Snail

22. Blade type:

Teflon

23. Blade diameter [mm]:

300

24. Useful Cut [mm]:

265 x210

25. On/Off button:

Yes

26. Continous work limit:

doba chodu bez omezení

Technical data sheet

Technical parameters



Slicer gear, blade 300 mm teflon

Model

SAP Code

00014116

27. Removable moving table:

Yes

28. Anti-adhesive blade treatment:

Yes

29. Table position:

Oblique

30. Blade cover material:

Stainless steel

31. Sharpening device:

Additional included in the price

32. Blade hardness:

58-59 HRC

33. Cutting thickness [mm]:

0 - 14

34. Cross-section of conductors CU [mm²]:

0,5

- Výkon (kW): 2,4-3,3 (230 V)